



**SMA Australia Pty.
Ltd.**
ABN: 44 127 198 761
Level 8, 76 Berry Street
North Sydney NSW
2060
Tel.: +61 1800 SMA

SMA Feedback on the 2025 Transition Plan for System Security

SMA-Australia welcomes the opportunity to provide feedback to the Australian Energy Market Operator (AEMO) regarding the 2025 Transition Plan for System Security.

SMA is a leading global specialist in photovoltaic (PV) system and battery energy storage system (BESS) power conversion and control technology. Our product range spans the home rooftop sector, commercial and industrial (C&I) applications, and large grid-scale applications. Our PV solar inverter and battery storage products are complemented by components for energy management, system monitoring, and data analysis. SMA has a global inverter capacity of 144 GW in more than 190 countries and more than 10 GW inverter capacity in Australia. We are headquartered in Germany, with employees in 19 countries. We are one of the world's leading manufacturers of grid forming (GFM) inverters.

The 2025 Transition Plan for System Security (TPSS) is a very welcome and useful contribution to planning the transition to a fully renewable electricity system. It integrates related pieces of work on system planning, technical standards, capability testing and development of new markets and technical requirements. It is helpful for its explanation of why, in AEMO's view, GFM BESS are not yet ready to fully substitute for rotating machines. The roadmap and process for demonstrating the unproven capabilities is very welcome.

It would be useful for AEMO to continue this approach in 2026, including details of progress with Type 2 Transitional Services in demonstrating the capabilities of GFM BESS.

In 2025 SMA established two controller hardware-in-the-loop (C-HIL) testing facilities in Australia. One is focused on pre-commissioning services for our customers and the other is part of a partnership with the University of Queensland. SMA also has advanced C-HIL testing facilities in Germany. We are keen to explore with AEMO how SMA could use our C-HIL testing facilities to demonstrate the capabilities of our GFM technology. We would also like to work with AEMO on validation in the field of the performance of BESS using SMA's GFM inverters.



**SMA Australia Pty.
Ltd.**

ABN: 44 127 198 761
Level 8, 76 Berry Street
North Sydney NSW
2060

Tel.: +61 1800 SMA

We look forward to working with AEMO as the Transition Plan for System Security progresses and as part of the framework and approach enabled by 'Type 2' Transitional Services contracts.



**SMA Australia Pty.
Ltd.**
ABN: 44 127 198 761
Level 8, 76 Berry Street
North Sydney NSW
2060
Tel.: +61 1800 SMA

Responses to Questions raised in the 2025 Transition Plan for System Security

1. What was most useful in this year's *Transition Plan for System Security* that would be useful in future?

As coal-fired generation retires from the National Electricity Market (NEM) and the South West Interconnected System (SWIS), a key challenge for system security will be to replace the system stability services that are currently provided by alternator-based generators (also known as synchronous generators), especially system strength.

An extremely useful aspect of the 2025 Transition Plan for System Security (TPSS) is the way that it brings together several crucial aspects of planning for system security into a single document. From the perspective of SMA Australia and our customers, the crucial aspects include:

- The Regional Transition plans, which incorporate the information and projections that were previously published in AEMO's detailed assessments of system strength, inertia and ancillary services shortfalls.
- The drivers of the projected shortfalls (retirement of coal-fired generation) and the plans for meeting projected shortfalls such as through investment in synchronous condensers or by extending the operating life of synchronous generators,
- AEMO's assessment of the barriers to using GFM BESS for provision of system security services and as an alternative to investment in new synchronous condensers,
- AEMO's plans to overcome the barriers to using GFM BESS for system security, and
- The role of Type 2 Transitional Services contracts to demonstrate the capability of GFM BESS for provision of grid stability services.

It would be useful for AEMO to continue this approach in 2026, including details of progress with Type 2 Transitional Services in demonstrating the capabilities of GFM BESS.

2. What additional information would help stakeholder decision-making on investments that support system security?



SMA Australia Pty. Ltd.
ABN: 44 127 198 761
Level 8, 76 Berry Street
North Sydney NSW
2060
Tel.: +61 1800 SMA

A key question for SMA is, “What evidence will AEMO and transmission network service providers (TNSPs) require to be persuaded that GFM BESS can reliably provide system security services as an alternative, not just a supplement, to synchronous generators and synchronous condensers?”

Although synchronous condensers are a well understood engineering solution to provide fault current, there are many known limitations with synchronous condensers. They are expensive and the lead times for procurement are long. The applications for which they can be used are limited. In contrast, GFM BESS are cheaper, more versatile, more readily available, and much faster to procure and construct.

3. Where is additional effort required to maintain system security while transitioning to higher contributions of renewables?

The TPSS and other AEMO publications have made it clear that the most significant remaining challenge is to demonstrate which GFM BESS systems can provide ‘protection quality’ fault current. SMA agrees that analysis of fault current performance and quantification of system strength from GFM BESS are foundational. Demonstrating the ability of GFM BESS to supply ‘protection quality’ fault current, would enable use of GFM BESS for minimum fault current levels. This is a prerequisite for managing grids without alternator-based generators or synchronous condensers.

The ability of GFM BESS to provide some system security services, such as inertia, are already well understood and sufficiently demonstrated. However, to replace (or more substantially supplement) investment in synchronous condensers, GFM BESS need to be able to demonstrate their capability to provide the full range of services needed as the NEM and SWIS transition and coal-fired power stations retire.

To our knowledge, the potential approaches that could be used to demonstrate the ability of GFM BESS to provide ‘protection quality’ fault current performance are:

- Grid modelling,
- Hardware in the loop (HIL) lab tests, and
- Validation of performance in the field.

The pros and cons of each potential approach are outlined below, along with suggestions for how SMA could contribute.



SMA Australia Pty. Ltd.
ABN: 44 127 198 761
Level 8, 76 Berry Street
North Sydney NSW
2060
Tel.: +61 1800 SMA

a. Grid modelling

In 2024 Aurecon advised Transgrid¹:

“The use of an integrated EMT model accounting for dynamic models of the IBR, network, loads and importantly protection systems which likely be impacted will be a key step to identify any residual concerns and gain confidence in overall system security after making the necessary modifications where required. This will be effectively an enhanced wide-area PSCAD model with dynamic models of the necessary relays included. Examples of relays of importance from a dynamic perspective include impedance-based relays such as distance, out-of-step and loss-of-excitation relays, and relays sometimes using negative-sequence current for decision making, such as differential, directional and overcurrent protection.”

SMA cannot undertake such grid modelling ourselves, but we would be pleased to contribute product information and other data that might be needed should such a modelling exercise be undertaken.

b. Research and use of HIL systems to assess technology capabilities

HIL testing is considered the most accurate method of simulation, short of testing on an operational system. Types of HIL facilities include ‘Controller HIL’ (C-HIL), ‘Software in the loop’ (SIL), and ‘Power HIL’ (P-HIL).

Controller HIL

Controller HIL (C-HIL) involves use of real control boards containing real firmware. C-HIL testing simulates the inputs with low voltage signals (e.g. +-10V) from a real time digital simulation (RTDS) of an electrical grid. The calculated signals (e.g. pulse width modulation (PWM) firing pulses for the power electronics) are gathered and fed back to the simulation. C-HIL does not involve large power and currents.

Advantages of C-HIL include:

- Original firmware and control hardware
- Tests for the same delays (e.g. communication)
- Tests the same firmware

¹ Aurecon (2024), ‘Advice on the maturity of grid forming inverter solutions for system strength’, report commissioned by Transgrid



**SMA Australia Pty.
Ltd.**
ABN: 44 127 198 761
Level 8, 76 Berry Street
North Sydney NSW
2060
Tel.: +61 1800 SMA

Disadvantages of C-HIL include:

- Does not provide information on some hardware capabilities such as thermal behavior, and overcurrent capabilities.
- Requires modification of control boards to be compatible with the RTDS. For example, SMA boards expect voltages of up to 1500V and not 10V. So, we must modify the measurement range, and every board is custom made.

In 2025, SMA provided necessary hardware and software as well as technical support to a research project conducted using the C-HIL testing facilities at the University of Queensland's power systems engineering lab based on the Eurimbula project. Eurimbula is a hybrid system comprised of 2x 280MW PV and 2x 333MW (2h) GFM BESS developed by Elements Green. The Australian Renewable Energy Agency (ARENA) is sponsoring the research project that will be conducted at UQ with the support of SMA and EPEC.

This research intends to demonstrate how hybrid systems and grid forming inverters can be best utilised to support the power grid and provide essential services to maintain or even improve power system security for Australia's future network without reliance on traditional alternator-based technologies.

SMA is also in discussion with the University of New South Wales (UNSW) regarding participation in its proposed project to use C-HIL testing facilities to quantify the ability of GFM technologies to provide system security services, such as 'protection quality' fault current.

SMA also has a C-HIL testing facility in Germany. The SMA C-HIL testing facilities in Brisbane and Germany have similar capabilities, although the German RTDS has more computing power. Figure 1 (below) shows the German C-HIL setup.



SMA Australia Pty. Ltd.
ABN: 44 127 198 761
Level 8, 76 Berry Street
North Sydney NSW
2060
Tel.: +61 1800 SMA

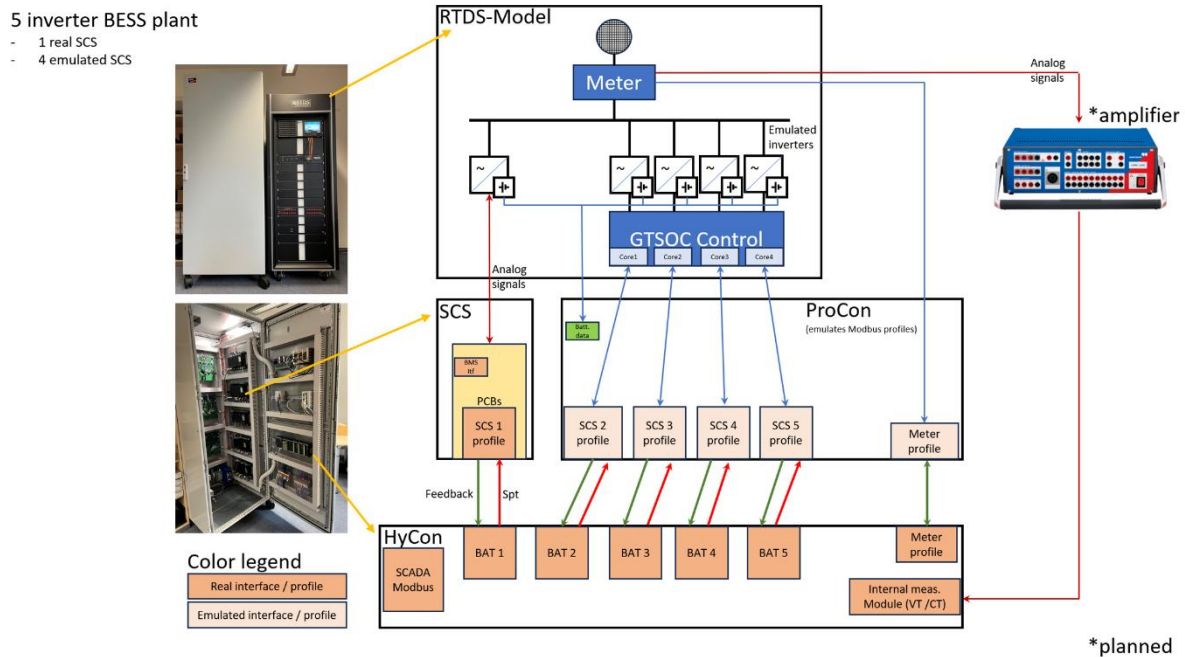

Figure 1 – The SMA C-HIL setup in Germany

Software in the loop

Software in the loop (SIL) testing does not include the real control boards. It could feature a specific part of the real control software (e.g. the control code of a signal processor), but it may lack other parts like the software on the communication board. Thus, it may not give the exact same behavior as the real component.

SIL is often used when the component you want to test is not really the focus. For example, in a test of the response of a real protection relay to the negative sequence current contribution of an inverter, the relay might be subjected to signals from a SIL simulation of an inverter that adequately represents the behavior.

Power HIL

Power HIL (P-HIL) requires a multi-megawatt, multi-million-dollar grid simulator that can test not only for the control boards, but for the full inverter. A P-HIL typically involves a high power, high frequency bandwidth AC voltage source that is controlled by a RTDS. On the simulator, you calculate the electrical grid and then you feed the calculated voltage to



**SMA Australia Pty.
Ltd.**
ABN: 44 127 198 761
Level 8, 76 Berry Street
North Sydney NSW
2060
Tel.: +61 1800 SMA

the AC source. The inverter then reacts, and the output current is then fed back to the real time simulator, closing the loop.

SMA is aware of two P-HIL testing facilities with high bandwidth voltage sources. They are located at the National Laboratory of the Rockies (formerly known as the National Renewable Energy Laboratory or NREL) Clempson University. Both are in the USA.

c. Validation of performance in the field

The ultimate test will be the validation of the performance of GFM BESS in the field in response to fault conditions. SMA has operational data from GFM BESS projects in Europe, including data about fault current performance in response to grid faults. We are working with the project owners of the GFM BESS to prepare the data for publication. We plan to present the data at the CIGRE conference in Paris in August 2026.

We understand that TNSPs might want to see the operational performance data from GFM BESS on Australian grids, rather than overseas grids. There are a growing number of systems that use SMA GFM inverters approved for connection to the grid. We anticipate that the Origin project in Mortlake could be the first of those commissioned and operating.

e. Definition and quantification of ‘protection quality’

SMA has plans to publish data on fault current performance of European GFM projects later in 2025. However, the planned publication will not demonstrate ‘protection quality’ fault current because further data is needed before we can understand what is required to qualify as ‘protection quality’ fault current. This is likely to be determined by the legacy protection devices installed on the grid and so the definition of ‘protection quality’ could vary from one grid to the next.

To assist with understanding what AEMO means by ‘protection quality’, we would welcome:

- A clear articulation of the problem statement regarding ‘protection quality’ fault current,
- An outline of how AEMO plans to determine whether fault current performance qualifies as ‘protection quality’ fault current
- Information on whether any standards exist for ‘protection quality’ fault current,



**SMA Australia Pty.
Ltd.**
ABN: 44 127 198 761
Level 8, 76 Berry Street
North Sydney NSW
2060
Tel.: +61 1800 SMA

- Whether AEMO intends to gather data on the performance characteristics of legacy protection equipment installed on the NEM,
- Whether TNSPs and distribution network service providers (DNSPs) retain an inventory of protection devices on their grids and whether there are plans for this to be published,
- Whether data on the performance characteristics of legacy protection devices on the NEM will be made publicly available.

4. How best should the Engineering Roadmap content be merged and balanced with the system security information in the *Transition Plan for System Security?*

SMA strongly supports the activities related to system strength and GFM BESS which are outlined in the Engineering Roadmap FY26 Priority Actions Report.

We intend to put resources into the following proposed activities:

- analysis of the fault current performance from GFM BESS,
- quantifying system strength support from GFM,
- a pre-commissioning test plan for GFM BESS,
- amendments to the System Strength Impact Assessment Guidelines (SSIAG)
- introduction of a system strength regime in the SWIS, and
- a pathway to substituting synchronous capability in the SWIS.

5. Do you have any feedback on how AEMO can / should continue to engage on technical matters?

SMA would appreciate AEMO providing regular updates on:

- Its understanding of progress internationally and within Australia to demonstrate the capabilities of GFM BESS



**SMA Australia Pty.
Ltd.**

ABN: 44 127 198 761
Level 8, 76 Berry Street
North Sydney NSW
2060

Tel.: +61 1800 SMA

- Its thresholds for evidence that would satisfy AEMO that GFM BESS are a reliable source of system security services
- Any relevant standards or testing procedures that would assist in demonstrating the capabilities of GFM BESS

We would appreciate AEMO outlining what it sees as its role and what it sees as the roles for DNSPs, TNSPs and suppliers of protection equipment in compiling an inventory of legacy protection equipment, publishing the performance characteristics of the protection equipment, and describing testing procedures to verify whether GFM BESS are considered capable of providing the ‘protection quality’ fault current that is required by the relevant protection equipment to be tested against.

The 2025 Transition Plan for System Security is an exciting opportunity to commence work to demonstrate the that making use of the full capabilities of GFM BESS can enable synchronous generation to be retired while maintaining system stability without relying on expensive synchronous condensers. SMA is very keen to work with AEMO as the plans for the 2025 Transition Plan for System Security are progressed.