

METROLOGY PROCEDURE PART A

NATIONAL ELECTRICITY MARKET

Prepared by: AEMO Markets

Document ref:

Version: 8.0

Effective date: 1 December 2025

Status: FINAL

Approved for distribution and use by:

Approved by: Michael Gatt

Title: Executive General Manager – Operations

Date: 30 June 2025

aemo.com.au

New South Wales | Queensland | South Australia | Victoria | Australian Capital Territory | Tasmania | Western Australia

Australian Energy Market Operator Ltd ABN 94 072 010 327

Contents

1. Introduction	5
1.1. Purpose and scope	5
1.2. Definitions and interpretation	5
1.3. Related AEMO documents	5
2. Responsibility for Metering Provision	6
3. Metering installation components	6
3.1. Requirements under National Measurement Act and use of Standards	6
3.2. Use of optical ports and pulse outputs	7
3.3. Password allocation	7
3.4. “x” values – calculation and use	7
3.5. “y” values – calculation and use	9
3.6. Grandfathering	10
3.7. Data storage requirements for meters	10
3.8. Metering installation clock	11
3.9. Interval meters	11
3.10. Alarm settings	11
4. Minimum Services Specification	12
4.1. Minimum service levels	12
4.2. Technical requirements	12
5. Summation metering	13
5.1. Legacy Summation Arrangements	13
5.2. New Metering Installation Summation Arrangements	13
5.3. Summation method	14
6. Embedded networks	14
7. Reversion of metering installation types	15
8. Routine testing and inspection of metering installations	15
9. Installation of meter(s)	15
9.1. General requirements	15
9.2. Type 4A metering installations only	16
10. Meter Churn	16
10.1. Initiation of a meter churn	16
10.2. Performance of a meter churn	16
10.3. Meter churn process	16
11. De-commissioning and removal of metering equipment and network devices	16
11.1. Preliminary requirements	16
11.2. Network devices	17
12. Responsibility for Metering data Services	17
12.1. Metering data services	17

12.2. Metering data collection	18
12.3. Metering data storage	20
12.4. Access to metering data	20
12.5. Verification of metering data for whole current metering installations for small customers and Type 7 metering installations	20
12.6. Metering installation Type 7 – sample testing	21
12.7. Request for test of calculated metering data	23
12.8. Request for test of SAPS calculated metering data	23
12.9. AEMO’s Metering data obligations	23
13. Emergency Priority Procedures	24
13.1. Criteria for determining emergency condition	24
13.2. Metering installations affected	24
13.3. Prioritisation of services by MC in emergency condition	25
13.4. Other laws prevail	25
14. Shared Fuse Arrangements	25

Tables

Table 1 Minimum Service Levels, Standards and Completion Rates	12
Table 2 Unmetered Devices in Inventory Table	22

Current version release details

Version	Effective date	Summary of changes
3.0	31 October 2011	Updated to incorporate provisions of Rule Change: Provision of <i>Metering data Services and Clarification of Existing Metrology Requirements.</i>
3.01	1 July 2012	Updated to incorporate jurisdictional material in relation to Queensland Retail Tariff Reform
3.10	1 January 2014	Introduction of FRC in Tasmania
3.20	1 March 2014	Updated to incorporate provisions of <i>Rules Change: National Electricity Amendment (Small Generation Aggregator Framework)</i> Rule 2012 ERC 0141 and text corrections.
5.30	15 May 2015	Updated to align version numbering with Metrology Procedure: Part B and to include corrections
6.00	1 December 2017	Updated to incorporate: <ul style="list-style-type: none"> National Electricity Amendment (Expanding competition in metering and related services) Rule 2015. No.12; National Electricity Amendment (Embedded Networks) Rule 2015 No. 15; and National Electricity Amendment (Meter Replacement Processes) Rule 2016 No. 2.
6.01	1 December 2017	Updated to incorporate a number of clarifications and corrections..
6.02	1 December 2017	Updated with feedback from PoC Work Package 3 first stage consultation

3.0	31 October 2011	Updated to incorporate provisions of Rule Change: Provision of <i>Metering data Services</i> and Clarification of Existing Metrology Requirements.
6.03	1 December 2017	Final version.
6.04	1 December 2017	Added Jurisdictional x-values for type 4A <i>metering installations</i>
6.05	20 May 2020	Updated to include IEC61869 in the CT and VT Standards, and clarify the <i>Validation of Metering data</i> for whole current Small Customer <i>Metering installations</i> , Type 4A, 5, 6 and 7 <i>Metering installations</i> .
7.0	1 October 2021	Updated for National Electricity Amendment (Five Minute Settlement) Rule 2017 No. 15
7.01	1 October 2021	V6.05 and v7.0 consolidated
7.1	1 May 2022	Updated to incorporate National Electricity Amendment (Global Settlement and Market Reconciliation) Rule 2018 No 14
7.2	N/A	Version number not used
7.3	1 May 2022	Updated to incorporate National Electricity Amendment (Introduction of metering coordinator planned interruptions) Rule 2020 No. 7
7.31	1 May 2022	Updated to include changes for the Metering ICF Package 2020 consultation, the changes are for the following Information Change Requests (ICFs): <ul style="list-style-type: none"> • ICF_019 Metrology Procedure sampling methodology • ICF_020 Changes to the clause 4.2 of the SLP to avoid confusion with the terms validation vs verification
7.4	1 May 2022	Clarified clauses and updated Australian Standard References according to October Retail Electricity Consultation. Consolidated versions v7.1, v7.3 and v7.31.
7.4	TBC	Updated to incorporate National Electricity Amendment (Regulated stand-alone power systems) Rule 2022
7.6	2 June 2024	Updated for National Electricity Amendment (Integrating energy storage systems into the NEM) Rule 2021
7.7	1 September 2024	Removal of NSW controlled load profile
7.81	4 November 2024	The procedure has been updated to reflect the changes consulted on for version 7.51 and to align the version number with Metrology Procedure Part B.
7.9	1 July 2025	Removal of SA controlled load profile and SA metering installation reversion provisions
8.0	1 December 2025	Updated for National Electricity Amendment (Accelerating smart meter deployment) Rule 2024 No.20 – testing and inspection

1. Introduction

1.1. Purpose and scope

This is the Metrology Procedure: Part A (**Procedure**), made under clauses 7.16.3, 7.16.4 and 7.16.5 of the National Electricity Rules (NER). This document also contains, for the sake of convenience, the following procedures:

- (a) *minimum services specification* procedures, which AEMO is required to *publish* under clause 7.8.3(b) of the NER;
- (b) *emergency priority* procedures, which AEMO is required to *publish* under clause 7.8.5(b) of the NER;
- (c) *network device* procedures, which AEMO is required to *publish* under clause 7.8.6(1) of the NER; and
- (d) *meter churn* procedures, which AEMO is required to *publish* under clause 7.8.9(f) of the NER.

This Procedure has effect only for the purposes set out in the NER. The NER and the *National Electricity Law* prevail over this Procedure to the extent of any inconsistency.

1.2. Definitions and interpretation

Terms defined in the *National Electricity Law* and the NER have the same meanings in these Procedures unless otherwise specified in this clause.

Terms defined in the NER are intended to be identified in these Procedures by italicising them, but failure to italicise a defined term does not affect its meaning.

The Retail Electricity Market Procedures – Glossary and Framework:

- (a) is incorporated into and forms part of this Procedure; and
- (b) should be read in conjunction with this Procedure.

1.3. Related AEMO documents

Title	Location
Retail Electricity Market Procedures – Glossary and Framework	http://aemo.com.au/Electricity/National-Electricity-Market-NEM/Retail-and-metering/Glossary-and-Framework
Metrology Procedure: Part B	http://www.aemo.com.au/Electricity/National-Electricity-Market-NEM/Retail-and-metering/Metrology-Procedures-and-Unmetered-Loads
Metrology Procedure: Part C	https://aemo.com.au/energy-systems/electricity/national-electricity-market-nem/market-operations/retail-and-metering/metrology-procedures-and-unmetered-loads
Service Level Procedure (MDP)	http://www.aemo.com.au/Electricity/National-Electricity-Market-NEM/Retail-and-metering/Metering-procedures-guidelines-and-processes

Service Level Procedure (MP)

<http://www.aemo.com.au/Electricity/National-Electricity-Market-NEM/Retail-and-metering/Metering-procedures-guidelines-and-processes>

2. Responsibility for Metering Provision

- (a) MCs must use MPs to provide, install, test and maintain the relevant components, characteristics and service requirements of the *metering installation* as specified in the NER and this Procedure, as appropriate.
- (b) MCs are responsible for the design of a *metering installation* and warrant that the design complies with the components, characteristics and service requirements specified in the NER and this Procedure.
- (c) MCs must ensure the components have been selected, installed, tested and commissioned by the MPs so that the *metering installation* satisfies the relevant accuracy and performance requirements in the NER and this Procedure.
- (d) An MP must be able to provide detailed specification and design requirements for those *metering installations* for which accreditation has been provided.

3. Metering installation components

The components, their characteristics, and associated service requirements for *metering installations* not detailed in the NER are detailed in this section.

3.1. Requirements under National Measurement Act and use of Standards

- (a) *Meters*¹ used in type 1, 2, 3, 4, 4A, 5, and 6 *metering installations* must comply with all applicable specifications or guidelines (including transitional arrangements) specified by the National Measurement Institute under the *National Measurement Act*, and must also meet all requirements of *Australian Standards* and International Standards:
 - (i) For type 1, 2, 3, 4, 4A, and 5 (including type 3 and 4 whole *current*) *metering installation measurement elements*: AS 62052.11, AS 62053.21 and AS 62053.22.
 - (ii) For type 6 *metering installation measurement elements*: AS 1284.1, AS 62053.21 and AS 62052.11.
- (b) CTs for type 1, 2, 3, 4, 4A, 5 and 6 *metering installations*, must meet the requirements of AS AS 61869.1 (General Requirements), AS 61869.2 (CT) and AS 61869.4 (combined transformers) or IEC 61869.1 (General Requirements) and IEC 61869.2 (CT) and must also comply with any applicable specifications or guidelines specified by the National Measurement Institute under the *National Measurement Act*.
- (c) VTs for type 1, 2, 3, 4, 5 and 6 *metering installations*, must meet the requirements of AS AS 61869.1 (General Requirements), AS 61869.3 (Inductive VT), AS 61869.4 (combined transformers), AS AS 61869.5 (Capacitor VT) and AS 1243 (three-phase VT) or IEC 61869.1 (General Requirements) and IEC 61869.3 (Inductive VT) and must also comply

¹ Refers to newly installed meters and reinstalled refurbished meters.

- with any applicable specifications or guidelines (including transitional arrangements) specified by the National Measurement Institute under the *National Measurement Act*.
- (d) Newly purchased CTs and VTs must comply with current *Australian Standards* as identified in paragraphs (b) and (c) or International Standards as identified in paragraphs (b) and (c).
 - (e) In-service and grandfathered CTs and VTs must comply with the *Australian Standard* that applied at the time of installation (for in-service) or purchase (for grandfathered).
 - (f) Unless otherwise permitted by the NER, the MC must ensure that new *meters* and related equipment used at a *connection point* have a valid pattern approval issued under the authority of the National Measurement Institute or, until relevant pattern approvals exist, a valid type test certificate issued by a National Association of Testing Authorities (NATA) accredited laboratory or a body recognised by NATA under the ILAC mutual recognition scheme. Relevant approval certificates must be provided to AEMO on request.
 - (g) A visible display or an equivalently accessible display must be provided to display, at a minimum, the cumulative total *energy* for each register measured by that *metering installation*.
 - (h) Any programmable settings available within the *metering installation*, or any peripheral device that will affect the resolution of displayed or stored data, must meet the relevant requirements of AS 62052.11, AS 62053.21 and AS 62053.22 and must comply with any applicable specifications or guidelines specified by the National Measurement Institute under the *National Measurement Act*.

3.2. Use of optical ports and pulse outputs

- (a) Where requested by a FRMP, the MC must provide pulse output facilities representing the quantity of electricity measured in accordance with the relevant *Australian Standard* for that *meter* within a reasonable time of receiving the request.
- (b) For type 1, 2, 3, 4, 4A and 5 *metering installations* with a pulse output, the *measurement element* pulse output must provide a number of energy pulses in each integrating period commensurate with the accuracy class of the *metering installation* when operating at the top of the range of measurement of the *metering installation* but may be set at a lower rate where the anticipated operating range is significantly lower than the top of the range of measurement of the *metering installation*.
- (c) A type 4A or 5 *metering installation* must have an optical port that meets the AS 1284.10.2 or AS 62056.21 or a computer serial port to facilitate downloading of 90 *days* of *interval energy data* for each *Datastream* associated with the *metering installation* in 90 seconds or less.

3.3. Password allocation

The MP must allocate “read-only” passwords to FRMPs, LNSPs and AEMO, except where separate “read-only” and “write” passwords are not available, in which case the MP must allocate a password to AEMO and the MDP only.

3.4. “x” values – calculation and use

- (a) For *connection points* with a type 5 *metering installation*, the volume of electricity flowing through the *connection point* is to be less than “x” megawatt hour (MWh) per annum, where “x” varies according to Jurisdiction, except for *first-tier load* type 5 *metering installations* that meet clause 11.20.3(a) of the NER.

- (b) The type 5 *metering installation* values of “x” applicable to a Jurisdiction are specified in the following table:

Jurisdiction	Variation in accordance with Jurisdictional policy
Victoria New South Wales South Australia Australian Capital Territory	Value of “x” is 160 MWh per annum
Queensland Tasmania	Value of “x” is zero (0) MWh per annum.

- (c) For *connection points* with a type 4A *metering installation*, the volume of electricity flowing through the *connection point* is to be less than “x” MWh per annum, where “x” varies according to Jurisdiction.
- (d) The type 4A *metering installation* values of “x” applicable to a Jurisdiction are specified in the following table:

Jurisdiction	Variation in accordance with Jurisdictional policy
Australian Capital Territory New South Wales Queensland	Value of “x” is 100 MWh per annum
South Australia	Value of “x” is 160 MWh per annum
Tasmania	Value of “x” is 150 MWh per annum
Victoria	Value of “x” is zero (0) MWh per annum

- (e) *Connection points* must not be aggregated when determining the annual consumption or the ADL as the basis of the comparison with the volume threshold for “x”
- (f) The manner in which the volumes of electricity referred to in the table above are to be calculated in each Jurisdiction is specified in the following table:

Jurisdiction	Variation in accordance with Jurisdictional policy
Victoria New South Wales Queensland	The volume threshold for a <i>connection point</i> must be determined from the annual consumption for the <i>billing periods</i> over the most recent 12 month period, or prorated over a 12-month period based on the Average Daily Load where consumption over the most recent 12 month period is not available. Where no <i>metering data</i> is available, the annual consumption may be calculated based on an engineering report or <i>metering data</i> from the <i>loads</i> of similar customers.
South Australia	The volume threshold for a <i>connection point</i> must be determined from: <ol style="list-style-type: none"> (1) the consumption at that connection point for any period of 12 consecutive months in the previous 2-year period, or (2) where such consumption data is not available or has not been accurately recorded, a calculation of the annual consumption at that connection point taking into account past electricity consumption levels, the electricity consumption capacity of plant and equipment, the operations for which electricity is required and any other matter considered relevant.

Jurisdiction	Variation in accordance with Jurisdictional policy
Australian Capital Territory	<p>The volume threshold for a <i>connection point</i> must be determined from:</p> <ol style="list-style-type: none"> (1) the annual consumption over the most recent 12-month period, (2) the annual consumption over the most recent 12-month period plus an allowance of 2%; or (3) calculated where consumption over the most recent 12-month period is not available or has not been accurately recorded. Where no consumption data is available, the potential annual consumption may be calculated having regard to relevant circumstances including: <ol style="list-style-type: none"> (a) the consumption capacity of the <i>connection point</i> and the extent to which that capacity is likely to be utilised in the future; (b) any recent or proposed change in ownership or use of the Site supplied at the <i>connection point</i>; or (c) any recent or proposed increase in the consumption capacity of the <i>connection point</i>.

3.5. “y” values – calculation and use

- (a) For *connection points* with a type 6 *metering installation*, the volume of electricity flowing through the *connection point* is to be less than “y” MWh per annum, where “y” varies according to Jurisdiction, except for *first-tier load type 6 metering installations* that meet the requirements of clause 11.20.3(a) of the NER.
- (b) The value of “y” applicable to each Jurisdiction is specified in the following table:

Jurisdiction	Variation in accordance with Jurisdictional policy
Victoria South Australia Australian Capital Territory	Value of “y” is 160 MWh per annum.
New South Wales	Value of “y” is 100 MWh per annum.
Queensland	<p>Value of “y” is:</p> <ol style="list-style-type: none"> a) 750 MWh per annum for customers that are not <i>Queensland Market Customers</i> in accordance with (c), below, and, b) 100 MWh per annum for <i>Queensland Market Customers</i>. c) 100 MWh per annum for <i>end-use customers</i> where: <ol style="list-style-type: none"> (i) <i>card operated meters</i> are installed in accordance with the regulatory framework, or (ii) <i>meters</i> are installed temporarily in a place other than the <i>meter’s</i> permanent location.
Tasmania	Value of “y” is 150 MWh per annum.

- (c) *Connection points* must not be aggregated when determining the annual consumption or the ADL as the basis of the comparison with the volume threshold for “y”.
- (d) The manner in which the volumes of electricity flowing through *connection points* are to be determined is specified for each Jurisdiction in the following table:

Jurisdiction	Variation in accordance with Jurisdictional policy
Victoria South Australia New South Wales Queensland Tasmania	The volume threshold for a <i>connection point</i> must be determined from the annual consumption for the <i>billing periods</i> over the most recent 12-month period, or prorated over a 12-month period based on the Average Daily Load where consumption over the most recent 12-month period is not available. Where no <i>metering data</i> is available, the annual consumption may be estimated based on an engineering report or <i>metering data</i> from the <i>loads</i> of similar customers.
Australian Capital Territory	The volume threshold for a <i>connection point</i> must be determined from: <ol style="list-style-type: none"> (1) the annual consumption over the most recent 12-month period, (2) the annual consumption over the most recent 12-month period plus an allowance of 2%, or (3) <i>calculated</i> where consumption over the most recent 12-month period is not available or has not been accurately recorded. Where no <i>metering data</i> is available, the potential annual consumption may be estimated having regard to relevant circumstances including: <ol style="list-style-type: none"> (a) the consumption capacity of the <i>connection point</i> and the extent to which that capacity is likely to be utilised in the future; (b) any recent or proposed change in ownership or use of the Site supplied at the <i>connection point</i>; or (c) any recent or proposed increase in the consumption capacity of the <i>connection point</i>.

3.6. Grandfathering

- (a) *Meters* and components for a type 5 or 6 *metering installation*, which were installed, or which were held in stock prior to 1 July 2008.
and which met the requirements of a Jurisdiction at that time, are deemed to meet the requirements of the *metrology procedure*.
- (b) *Metering installations* that have been installed, or are held in stock for the MC in a Jurisdiction prior to the effective date of that Jurisdiction's initial metrology procedure and do not comply with the NER or the *metrology procedure*, may be used where approval from a *Jurisdictional Regulator* had been obtained prior to the effective date of the *metrology procedure* or approval is obtained from AEMO.
- (c) *First-tier load summation metering installations* that were commissioned prior to 1 July 2008 that complied with the Jurisdictional requirements as at this date and continue to meet the Jurisdictional requirements are taken to be NER and *metrology procedure* compliant. The summation *metering installations* are deemed non-compliant if they do not meet the applicable Jurisdictional accuracy standards at 30 June 2008. Defective *first-tier load summation metering installations* that were commissioned prior to 1 July 2008 must be repaired or replaced so as to ensure the summation *metering* meets the minimum standards in accordance with the NER and the *metrology procedure*.

3.7. Data storage requirements for meters

Section 3.7 supplements clause 7.8.2(a)(10) of the NER.

Components of a type 5 *metering installation* installed prior to 1 January 2007 must have the capability of storing *interval energy data* for a period of at least two Meter Reading cycles plus 15 days, or 35 days, whichever is the greater.

3.8. Metering installation clock

- (a) A type 4A, 5 or 6 *metering installation* clock is to be reset to within ± 20 seconds of *Eastern Standard Time* on each occasion that the *metering installation* is accessed in the circumstances referred to in paragraphs (a) and (b), and the maximum drift in the type 4A or 5 *metering installation* clock permitted between successive Meter Readings is ± 300 seconds.
 - (i) MP must reset a type 4A, 5 or 6 *metering installation* clock when inspecting, maintaining or commissioning the *metering installation*.
 - (ii) MDP must reset a type 4A, or 5 *metering installation* clock when *interval metering data* is collected from the *metering installation*.
- (b) A CT-connected type 5 *metering installation* with a slower download time than specified in section 3.2 may be used where approved by AEMO.
- (c) For type 6 *metering installations* with different time of day rates, the *metering installation* must meet AS 62054.11, AS 62054.21 and AS 62052.21, or have the switching between the different rates controlled by a frequency injection relay or time clock operated by the LNSP.

3.9. Interval meters

Where a *metering installation* records *interval energy data* the interval periods are based on TIs or parts of a TI:

- (a) The end of each interval for a 15-minute interval period must be on the hour, on the half-hour and on each quarter of an hour (*EST*).
- (b) The end of each interval for a 30-minute interval period must be on the hour and on the half-hour (*EST*).
- (c) Other sub-multiple intervals, where agreed with AEMO, the LNSP and the relevant Market Participant, provided that the ends of the intervals correspond each and every exact hour (*EST*) and half-hour (*EST*).

3.10. Alarm settings

- (a) Where an Interval Meter supports alarm functionality, the MP is required to enable the following alarms:
 - (i) power failure/*meter* loss of supply for instrument transformer connected *metering installations* only;
 - (ii) VT or phase failure;
 - (iii) pulse overflow;
 - (iv) cyclic redundancy check error; and
 - (v) time tolerance.
- (b) Where there are alarm sensitivity settings, these must be set at appropriate levels to ensure meaningful alarm outputs (e.g. for contestable supplies a voltage drop of -15% is nominally appropriate).

4. Minimum Services Specification

- (a) For a type 4 *metering installation* to become a *small customer metering installation*, it must meet the *minimum services specification*, which is specified in Schedule 7.5 of the NER.
- (b) The services set out in the *minimum services specification* apply to the capability of the *metering installation* itself.

4.1. Minimum service levels

The minimum service levels are made up of two elements: service availability and completion timeframes.

4.1.1. Service availability

Except for periods of a loss of *supply*, *metering installations* must be capable of meeting the *minimum services specification* at all times.

4.1.2. Completion timeframes

The completion timeframes for each service are detailed in Table 1. They will be measured from the time a request is received by the *metering installation* to the time of notification of completion of the relevant service by the *metering installation* appears at the communication interface at or near the *metering point(s)* where it is made available for collection.

4.1.3. Completion rates

- (a) The services and completion rates for each service are detailed in Table 1. The timeframes will be measured from the time a request is received by the *metering installation* to the time of completion of the relevant service by the *metering installation*.
- (b) Upon request from AEMO, the MC must be able to provide evidence demonstrating that *small customer metering installations* are capable of performing to the completion rates.

4.2. Technical requirements

A *small customer metering installation* must comply with the following technical requirements:

- (a) It must be capable of measuring *active energy* (Wh) and leading and lagging *reactive energy* (varh) for both import and export *energy flows*, i.e. 4 quadrant metering.
- (b) Where a poly-phase *metering device* is installed, the *metering installation* must be capable of recording and providing the average voltage and current per phase for all connected phases over one or more nominated TIs.

Table 1 Minimum Service Levels, Standards and Completion Rates

Service	Completion Timeframe	Completion Rate
Remote Disconnection Service	Completed within 1 minute of the command being received by the <i>metering installation</i>	99.5% completed within Minimum Service Levels

Remote Reconnection Service	Completed within 1 minute of the command being received by the <i>metering installation</i>	99.5% completed within Minimum Service Levels
Remote On-Demand Meter Read	Completed within 1 minute of the command being received by the <i>metering installation</i>	99.5% completed within Minimum Service Levels
Remote Scheduled Meter Read	Completed within 1 minute of the command being received by the <i>metering installation</i>	99.5% completed within Minimum Service Levels
<i>Metering installation</i> Inquiry	Completed within 1 minute of the command being received by the <i>metering installation</i>	99.5% completed within Minimum Service Levels
Advanced Meter Reconfiguration	Completed within 1 minute of the command being received by the <i>metering installation</i>	99.5% completed within Minimum Service Levels

5. Summation metering

These provisions set out the conditions under which summation metering may be used.

5.1. Legacy Summation Arrangements

These provisions are included to support legacy arrangements for existing *metering installations* where allowed by Jurisdictional transitional arrangements in Chapter 11 of the NER.

- (a) If summation *metering* is achieved by paralleling CT secondary circuits, the overall *metering installation* must meet the minimum standards and overall error for a new *metering installation* under all *load* combinations of the individual CT secondaries.
- (b) If summation *metering* is achieved by the arithmetic sum of data registers or the accumulation of pulses, each individual *metering point* must meet the minimum standards for a new *metering installation* and the MC must on request demonstrate that the summation techniques reliably and accurately transfer data.
- (c) CT secondary circuits can only be paralleled using appropriate arrangements of links terminating individual conductors; this must not be done at the *meter* terminals.
- (d) For type 2 *metering installations* only: Direct summation, in which secondary wiring from a multiple number of feeders is connected directly into the terminals of a *meter*, or summation CTs are permitted provided that the overall errors of the *metering installation* are considered.

5.2. New Metering Installation Summation Arrangements

Summation *metering* is only permitted for a single *connection point* as follows:

- (a) HV breaker-and-a-half schemes
- (b) HV single transformer fed by multiple paralleled cables; this must not involve multiple feeders
- (c) Cross boundary supply single transformer with multiple LV secondary circuits
- (d) Any proposed summation *metering* arrangement under (a), (b) and (c) must be approved by AEMO before implementation.
- (e) Any summation *metering* arrangement that is not described in (a), (b) or (c) must be presented to AEMO for consideration to be eligible for inclusion in the Metrology Procedure.

5.3. Summation method

These provisions detail the summation method that can be used for new summation *metering installations* described in 5.2.

- (a) Summation *metering* can be achieved by paralleling CT secondary circuits, provided the overall *metering installation* must meet the minimum standards and overall error performance requirements for a new *metering installation* under all *load* conditions for the *connection point* and its individual conductors as measured by individual CTs.
- (b) CT secondary circuits can only be paralleled using appropriate arrangements of links terminating individual conductors; this must not be done at the *meter* terminals.
- (c) The use of additional summation CTs within the *metering installation* is not permitted.

6. Embedded networks

The requirements in the following table only apply in the specified Jurisdiction:

Jurisdiction	Variation in accordance with Jurisdictional policy
South Australia	<p>Should a Child Metering Point in an <i>embedded network</i> elect to purchase electricity from a <i>retailer</i> other than the parent's <i>retailer</i>, the metering coordinator must ensure that:</p> <ul style="list-style-type: none"> (a) the <i>child</i> has an <i>interval meter</i> installed; and (b) the parent of the <i>embedded network</i> has an Interval Meter installed.
New South Wales	<ul style="list-style-type: none"> (1) Should a <i>child</i> in an <i>embedded network</i> elect to purchase electricity from a <i>retailer</i> other than the parent's <i>retailer</i>, the metering coordinator must ensure that, at the time the <i>child</i> switches <i>retailer</i> and at the cost of the <i>child</i>: <ul style="list-style-type: none"> (a) if the parent has an Interval Meter that is settled on the basis of <i>interval energy data</i>, the <i>child</i> must have a type 4 or type 5 <i>metering installation</i> that is settled on the basis of <i>interval energy data</i>; (b) if the parent has an Accumulation Meter or an Interval Meter that is settled on the basis of <i>accumulated energy data</i>, the <i>child</i> must have a type 6 <i>metering installation</i> or, if the <i>child</i> has an Interval Meter, it must be settled on the basis of <i>accumulated energy data</i>. (2) Where a <i>child</i> in an <i>embedded network</i> has switched <i>retailer</i> in accordance with clause [NSW](1)(b) above and the parent subsequently: <ul style="list-style-type: none"> (a) installs an Interval Meter and elects to have its meter settled on the basis of interval energy data; or (b) elects to have its existing Interval Meter settled on the basis of accumulated energy data in accordance with clause 12.2(b)[NSW](3); or (c) elects to have its existing Interval Meter settled on the basis of interval energy data, the MC must ensure that at the time the parent changes, and at the cost of the parent, the <i>child's metering installation</i> meets the requirements of paragraph (a) or (b) of [NSW](1), as applicable.

Australian Capital Territory	<ul style="list-style-type: none"> (1) The metering coordinator must ensure that the <i>metering installation</i> is not for a child in an embedded network. (2) Where the <i>metering installation</i> is for a child in an embedded network, the metering coordinator must ensure that additional metering is installed to ensure that clause [ACT](1) is met.
------------------------------	--

7. Reversion of metering installation types

- (a) Existing *metering installations* that produce TI *metering data* must not be reconfigured or replaced with a *metering installation* that produces 15 or 30-minute *metering data*.
- (b) The requirements in the following table only apply to the specified Jurisdiction:

Jurisdiction	Variation in accordance with Jurisdictional policy
Australian Capital Territory	<ul style="list-style-type: none"> (1) The metering coordinator must ensure that a type 4 or type 5 <i>metering installation</i> is not replaced by a type 6 <i>metering installation</i>. (2) The metering coordinator must ensure that where an Interval Meter is installed, the <i>metering installation</i> complies with the requirements of a type 4 or type 5 <i>metering installation</i>.
Queensland	<ul style="list-style-type: none"> (1) The metering coordinator must ensure that an Interval Meter is not replaced by an Accumulation Meter. (2) The metering coordinator must ensure that a sample Interval Meter installed for the purposes of calculating a CLP is not removed without the consent of the LNSP. (3) The metering coordinator must ensure that the energy measured by a sample Interval Meter installed for the purposes of calculating the CLP is settled in the market on the basis of a type 6 <i>metering installation</i>.

8. Routine testing and inspection of metering installations

- (a) The MC must provide an Asset Management Strategy to AEMO, for assessment and approval. When assessing for approval, AEMO must consider the merits of the Asset Management Strategy by considering its alignment with Metrology Procedure Part C.
- (b) The MC must provide a copy of the *asset management strategy* to each relevant MP.

9. Installation of meter(s)

9.1. General requirements

The MC must use reasonable endeavours to ensure that, at the time of installation, a *metering installation* is:

- (a) protected against damage;
- (b) installed in such a way that it allows safe and unimpeded access to the End User or any person whose obligation it is to test, adjust, maintain, repair, or replace the *metering installation*, or to collect *metering data* from the *metering installation*; and
- (c) available to the End User or any person whose obligation it is to test, adjust, maintain, repair, or replace the *metering installation*, or to collect *metering data* from the *metering installation* via safe, convenient and unhindered access when it is not located at the Site.

9.2. Type 4A metering installations only

The MC must ensure that when each *meter* of a *type 4A metering installation* is installed, it is checked such that it has the optical port, communications port and visual display located so that the optical port, communications port, or visual display can be readily accessed for Meter Reading.

10. Meter Churn

10.1. Initiation of a meter churn

The Current MC for a *metering installation* can initiate a Meter Churn at any time.

10.2. Performance of a meter churn

Only MPs with the appropriate accreditation can perform a Meter Churn.

10.3. Meter churn process

When a Meter Churn is initiated, the MC must ensure:

- (a) information is made available to any New MPB to facilitate the Meter Churn, which includes:
 - (i) the *NMI*;
 - (ii) the Site address;
 - (iii) the Meter Serial ID(s) of the *meter(s)* to be removed;
 - (iv) the names of the Current MPB and its Participant ID;
 - (v) the names of the Current MDP and its Participant ID;
 - (vi) the current *metering installation* type; and
 - (vii) instructions on the required changes;
- (b) all Role assignments in MSATS for the *connection point* comply with the MSATS Procedures within 2 *business days* of the Meter Churn; and
- (c) the Start Date for any New Category B Metering Provider (MPB) or New MDP is the *meter* change date.

11. De-commissioning and removal of metering equipment and network devices

11.1. Preliminary requirements

Before de-commissioning all or any part of an existing *metering installation*, including any *network device*, the MC must ensure that directions are provided to the MP undertaking the

work to return the removed *meter* or *network device* to its owner within 10 *business days* unless otherwise agreed with the owner.

11.2. Network devices

11.2.1. Deemed network devices

AEMO does not consider there to be any circumstances where it is necessary for AEMO to deem certain devices at or adjacent to a *metering installation* to be *network devices*, for the purposes of clause 7.8.6 of the NER.

11.2.2. Obligations if alterations to metering installations or network devices are required

- (a) Where an LNSP considers that an isolation or alteration is required to a *metering installation* to facilitate the installation, removal, or replacement of a *network device* at or near the *metering installation*, including the removal of any seal, the LNSP must:
 - (i) agree the isolations or alterations with the affected MC and MP prior to the commencement of any alterations;
 - (ii) ensure any work performed on the *metering installation* is undertaken by a suitably accredited MP; and
 - (iii) ensure that the MC and MP are provided with details of the isolation or alteration, including any new seals.
- (b) Where a *network device* needs to be altered to accommodate a change to the *metering installation*, including the removal of any seal, the MC must ensure that the LNSP is provided with details of the isolation or alteration, including any new seals.

11.2.3. Notifications following network device removal without LNSP consent

If an MC arranges for the removal of a *network device* in accordance with clause 7.8.6(f) of the NER, the MC must, in addition to providing the notifications required by clause 7.8.6(g) of the NER, provide the following records in electronic format to the LNSP:

- (a) the type, asset number and serial number of the *network device* removed, the name of the *network device* owner, where those details are provided on the *network device* itself; and
- (b) the type, asset number and serial number of any additional *network device* that was not removed, the name of the *network device* owner of any other *network device* where those details are provided on the *network device* itself.

12. Responsibility for Metering data Services

12.1. Metering data services

- (a) The MC or FRMP (as applicable) must use MDP(s) for the provision of *metering data services* in accordance with clauses 7.3.2 and 7.8.1 of the NER.

- (b) The MC or AEMO (as applicable) must ensure that the calculation, Validation, Substitution and Estimation of *metering data*, where appropriate, is undertaken in accordance with Metrology Procedure: Part B.

12.2. Metering data collection

- (a) For type 1, 2, 3, 4, 4A, 5 and 6 *metering installations*, an MC or AEMO (where applicable) must ensure that *metering data* is collected in accordance with the Service Level Procedure (MDP).
- (b) This requirement only applies to the Jurisdiction specified in the following table:

Jurisdiction	Variation in accordance with Jurisdictional policy
Victoria	The <i>type 5 accumulation boundary</i> is zero MWh per annum.
New South Wales	<p>(1) The <i>type 5 accumulation boundary</i> is 100 MWh per annum for type 5 <i>meters</i> installed prior to, or in the process of being installed as at 1 December 2017.</p> <p>(2) Where an Interval Meter has been installed, the metering coordinator must ensure that the reading of that Interval Meter may only be changed from being read as a <i>metering installation</i> type 5 to being read as a <i>metering installation</i> type 6 when:</p> <p>(a) a transfer of the customer to a New Retailer has been effected; or</p> <p>(b) the Interval Meter has been read as a <i>metering installation</i> type 5 for a period of at least 12 contiguous months with the existing <i>retailer</i>.</p>
South Australia	(1) The <i>type 5 accumulation boundary</i> is zero MWh per annum.
Australian Capital Territory	<p>(1) In accordance with section 7[ACT](2), the <i>type 5 accumulation boundary</i> is 100 MWh per annum.</p> <p>(2) If an Interval Meter has been installed for sites where the <i>type 5 accumulation boundary</i> is less than 100 MWh per annum, it may be read as a <i>metering installation</i> type 5 at any time.</p>
Queensland	The <i>type 5 accumulation boundary</i> is 750 MWh per annum.

- (c) This requirement only applies to the Jurisdiction specified in the following table:

Jurisdiction	Variation in accordance with Jurisdictional policy
Australian Capital Territory	Clause 3.4.6 does not apply to type 5 <i>metering installations</i> with consumption less than is specified in clause 12.2(b)[ACT](1) where that <i>metering installation</i> is being read as a type 6.

- (d) This requirement only applies to the Jurisdiction specified in the following table:

Jurisdiction	Variation in accordance with Jurisdictional policy
Australian Capital Territory	During the period in which the metering coordinator is not required to collect <i>interval energy data</i> from any type 5 <i>metering installation</i> because of the operation of clause 12.2(b)[ACT](2), if it does not collect <i>interval energy data</i> from that <i>metering installation</i> , it must collect <i>accumulation energy data</i> from that <i>metering installation</i> as if it were a type 6 <i>metering installation</i> .

- (e) This requirement only applies to the Jurisdiction specified in the following table:

Jurisdiction	Variation in accordance with Jurisdictional policy
Queensland	<p>(1) An Interval Meter installed at a <i>connection point</i> where the flow of electricity is less than 100MWh per annum will be read as an Accumulation Meter unless the <i>metering installation</i> is classified as types 1 to 4.</p> <p>(2) Subject to (3), an Interval Meter installed for a <i>Queensland Market Customer</i> where the flow of electricity is greater than or equal to 100 MWh per annum must be read as a remotely read Interval Meter.</p> <p>(3) Notwithstanding (2), an Interval Meter installed where the flow of electricity is greater than or equal to 100 MWh per annum and where the <i>connection point</i> has never had an customer with a <i>negotiated retail contract</i> will be read as an Accumulation Meter by the <i>metering data provider</i>.</p> <p>(4) A LNSP is permitted to read the <i>metering installation</i> for its own purpose provided the reading schedule is coordinated with the metering coordinator.</p>

- (f) For type 5 *metering installations* (excluding sample profile *meters* for the purposes of developing the CLPs in accordance with section 13.3 of Metrology Procedure: Part B), the MC must:
- (i) ensure that *interval metering data* is collected from a *metering installation* in accordance with the Service Level Procedure (MDP); and
 - (ii) use reasonable endeavours to ensure that *interval metering data* is collected from every type 5 *metering installation* once every three months and that this *metering data* is transferred to the *metering data services database*.
- (g) For type 6 *metering installations*, the MC must:
- (i) ensure that *accumulated energy data* is collected from *metering installations* in accordance with the Service Level Procedure (MDP); and
 - (ii) use reasonable endeavours to ensure that *accumulated energy data* is collected from every type 6 *metering installation* once every three months and that this *metering data* is transferred to the *metering data services database*.
- (h) An MC must use reasonable endeavours to ensure that *energy data* is collected from a type 4A, 5 or 6 *metering installation* and transferred to the relevant *metering data services database* no more than two *business days* prior to, or two *business days* subsequent to, the Scheduled Reading Date for that *metering installation*.
- (i) This requirement only applies to the Jurisdiction specified in the following table:

Jurisdiction	Variation in accordance with Jurisdictional policy
Victoria	Despite 12.2(h), where <i>metering data</i> for a type 5 <i>metering installation</i> is collected by <i>remote acquisition</i> , <i>metering data</i> is to be transferred to the <i>metering data services database</i> in accordance with the AMI Service Levels Specification (Victoria) (published on the Department's website on 18 October 2007) and as amended from time to time.

- (j) For *metering installations* that do not have *remote acquisition*, and where an MC is not a TNSP, the MC must use reasonable endeavours to ensure that each *metering installation* is read at least every three months, and the Meter Reading frequency is agreed with the FRMP.
- (k) When the MC is informed of a *metering data* collection issue, the MC must:
- (i) within 15 *business days*, take the necessary steps to ensure the missing *metering data* collected;

- (ii) ensure that the *metering installations' communications interface* is maintained to facilitate ongoing collection of *metering data*;
- (iii) ensure that *metering data* is collected at a frequency that is within the energy data storage capacity of that *metering installation* such that the *metering data* collection process prevents the loss of actual *metering data*; and
- (iv) ensure that, irrespective of the energy storage capacity of the *metering installation*, the *metering installation* reading frequency must not exceed three months since the last actual read was undertaken.

12.3. Metering data storage

- (a) The MDP must provide a *metering data services database* containing *metering data* in accordance with clause 7.10.1 of the NER.
- (b) The Load Tables, Inventory Tables and On/Off Tables for type 7 *metering installations* and Inventory Tables, calculation methodologies and Agreed Loads for *non-contestable unmetered loads* must be stored within the *metering data services database*.

12.4. Access to metering data

- (a) Access to *metering data* must be provided in accordance with clause 7.15.5 of the NER and the Service Level Procedure (MDP).
- (b) The MC must ensure that *metering data* from the following is transferred to AEMO:
 - (i) *interval metering data* for all loads, including Controlled Loads and calculated *metering data* for type 7 *metering installations* and *non-contestable unmetered loads*;
 - (ii) *accumulated metering data* for all Controlled Loads and Non-Controlled Loads; and
 - (iii) *interval metering data* for *market connection points* for a *market generating unit*, in a *regulated SAPS*.

12.5. Verification of metering data for whole current metering installations for small customers and Type 7 metering installations

To facilitate the verification of *metering data* for whole current *metering installations* and type 7 *metering installations*:

- (a) Each MC must ensure that a Sample Test Plan is established and maintained in accordance with *Australian Standards* "AS 1199: Sampling procedures for inspection by attributes – Sampling schemes indexed by Acceptance Quality Limit (AQL) for lot-by-lot inspection".
- (b) Each MC must ensure that the Sample Test Plan is set at General Inspection Level II and initially selected to be a normal inspection sample size using an AQL of 1.5.
- (c) A test sample is deemed to have passed the verification test when the *metering data* stored in the *metering data services database* is consistent with the *energy data* stored in the *metering installation*. If the *metering data* stored in the *metering data services database* does not match the *energy data* stored in the *metering installation*, then the test sample is deemed to have failed the verification test and must be rectified.

- (d) Each MC must ensure the following steps are taken after each round of verification:
 - (i) If the Sample Test Plan passes the acceptance number (A_c) criteria at a normal inspection sample size, continue to test using the normal inspection sample size for the next round.
 - (ii) If the Sample Test Plan fails the acceptance number (A_c) criteria at a normal inspection sample size, switch to a tightened inspection sample size for the next two rounds. If the two consecutive rounds pass, then on the third round switch back to a normal inspection sample size.
 - (iii) If the Sample Test Plan fails the acceptance number (A_c) criteria for two consecutive rounds, then all *metering installations* will need to be verified.
- (e) Verification tests must be conducted in accordance with the Sample Test Plan, at least once every 12 months.
- (f) If there is an inconsistency between the *energy data* held in a *metering installation* and the *metering data* held in the *metering data services database*, the *energy data* in the *metering installation* is to be taken as prima facie evidence of the amount of electricity supplied to that *metering point*, except if the *meter* or components of the *metering installation* are found to be not compliant with the NER.
- (g) The *calculated metering data* stored in a *metering data services database* for a *NMI* is consistent with the Physical Inventory if the error associated with calculating the *energy* value for the sample, that is:

$$\frac{\sum_{i=1}^n (\text{Agreed load per Unmetered Device as per Load Table})_i * (\text{Actual number of Unmetered Device in the sample geographic area})_i}{\sum_{i=1}^n (\text{Agreed load per Unmetered Device as per Load Table})_i * (\text{Number of Unmetered Device in the sample geographic area as per Inventory Table})_i} - 1$$

where: i = Unmetered Device

is within $\pm 2.0\%$. Where the existing error is greater than $\pm 2.0\%$ a date for reaching an error level within $\pm 2.0\%$ and a transition plan to reach that error level must be determined by AEMO in consultation with the relevant MC and affected *Registered Participants*.

- (h) If there is an inconsistency between the Inventory Table held in a *metering data services database* for a *type 7 metering installation* and the Physical Inventory, the Physical Inventory is to be taken as prima facie evidence of the actual number of Unmetered Devices.

12.6. Metering installation Type 7 – sample testing

- (a) For the purposes of sample testing *type 7 metering installations*, the MC must ensure that the sample size is determined using Table 2. The sample is to be selected from Unmetered Devices in the Inventory Table for an MC.
- (b) The MC must ensure that the sample size for the first two Validation tests is based on a ‘normal’ sample size indicated in Table 2.

Table 2 Unmetered Devices in Inventory Table

Number of Unmetered Devices in Inventory Table	Sample Size		
	Reduced	Normal	Tightened
2 to 8	2	2	3
9 to 15	2	3	5
16 to 25	3	5	8
26 to 50	5	8	13
51 to 90	5	13	20
91 to 150	8	20	32
151 to 280	13	32	50
281 to 500	20	50	80
501 to 1200	32	80	125
1201 to 3200	50	125	200
3201 to 10000	80	200	315
10001 to 35000	125	315	500
35001 to 150000	200	500	800
150001 to 500000	315	800	1250
500001 to over	500	1250	2000

(c) The MC must ensure that the sample size for subsequent Validation tests is based on the following:

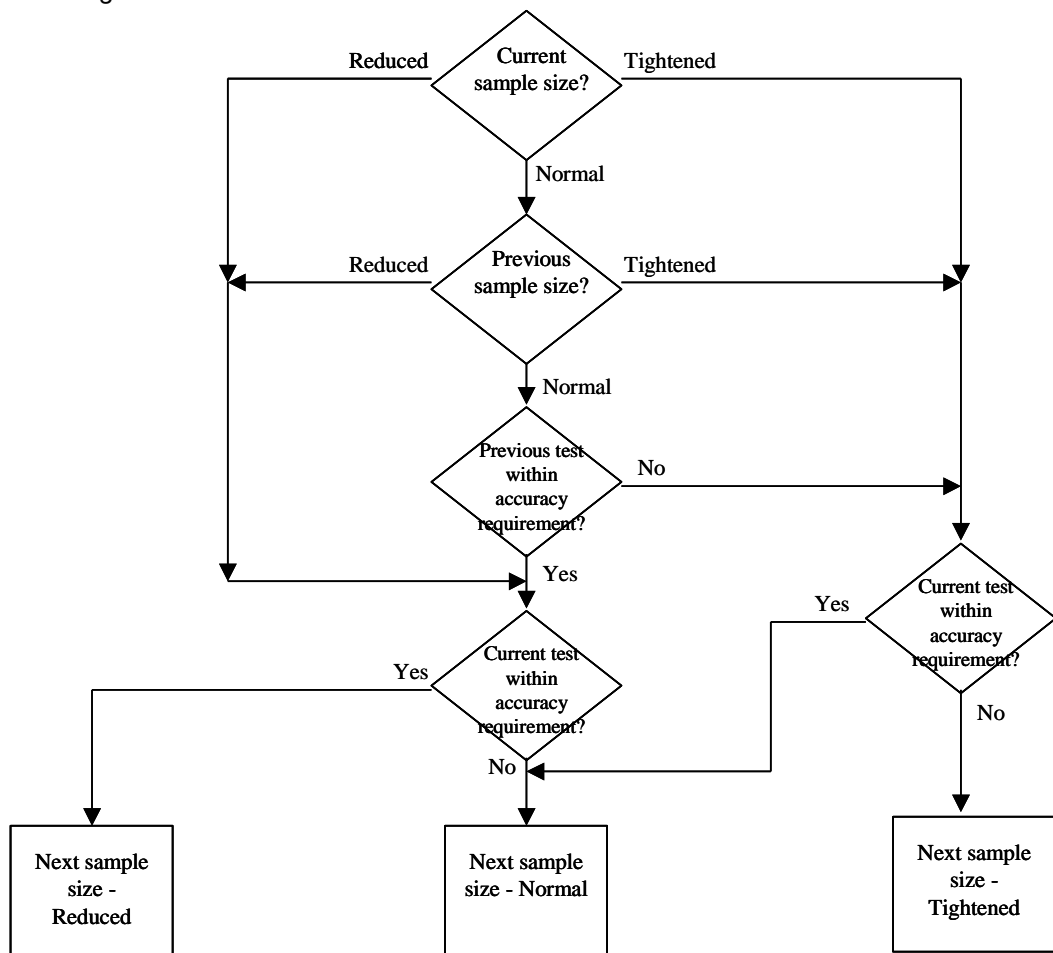

- (d) The MC must select sample Unmetered Devices for a Validation test from random geographic areas depending on the sample size. The selection of the geographic area must be such that each Unmetered Device has an equal chance of being included in the sample.
- (e) The MC must ensure that the Validation test is conducted at least once every six months, commencing from the first Validation test.
- (f) If the results of two consecutive Validation tests, based on a reduced sample size, be within the accuracy requirements for that test, the MC must ensure that the next Validation test is conducted at least once every 12 months.

12.7. Request for test of calculated metering data

- (a) If requested to test a type 7 *metering installation* by a *Registered Participant* under clause 7.9.1 of the NER, the MC or AEMO (as applicable) must:
 - i. arrange to test that the *calculated metering data* stored in the *metering data services database* reflects the Physical Inventory for the type 7 *metering installation*;
 - ii. arrange to test that the *calculated metering data* stored in the *metering data services database* reflects the Physical Inventory, calculation methodology and Agreed Load for the *non-contestable unmetered load*;
 - iii. use reasonable endeavours to conduct the test within 15 *business days* of the request; and
 - iv. prior to any test being undertaken, provide an estimate of costs associated with the test.
- (b) Where there is a discrepancy between the Inventory Table held in the *metering data services database* for a type 7 *metering installation* and the Physical Inventory, the Physical Inventory is to be taken as prima facie evidence of the actual number of Unmetered Devices.
- (c) Where there is a discrepancy between the Inventory Table held in the *metering data services database* for a *non-contestable unmetered load* and the Physical Inventory, the Physical Inventory is to be taken as prima facie evidence of the actual number of Unmetered Devices.

12.8. Request for test of SAPS calculated metering data

- (a) If requested to test a *metering installation* at a *market connection point* for a *market generating unit*, in a *regulated SAPS* by a *Registered Participant* under clause 7.9.1 of the NER, the MC or AEMO (as applicable) must:
 - i. arrange to test that the *calculated metering data* stored in the *metering data services database* reflects the calculation methodology for the *regulated SAPS*;
 - ii. use reasonable endeavours to conduct the test within 15 *business days* of the request; and
 - iii. prior to any test being undertaken, provide an estimate of costs associated with the test.

12.9. AEMO's Metering data obligations

12.9.1. Substitutions

Where *metering data* has been Substituted, AEMO must advise affected *Registered Participants* at the same time as that *metering data* is sent to *Market Participants* for *settlements*.

12.9.2. Load profiling

- (a) This requirement only applies to the Jurisdiction specified in the following table:

Jurisdiction	Variation in accordance with Jurisdictional policy
Queensland	AEMO must prepare a CLP for each relevant Profile Area in accordance with sections 11.4 and 11.5 of Metrology Procedure Part B apply the CLP(s) by Profile Area to the consumption energy data from the applicable first tier controlled load Accumulation Meters and from the applicable Second Tier Controlled Load type 6 <i>metering installations</i> in accordance sections 11.4 and 11.5 of Metrology Procedure Part B to produce <i>interval metering data</i> . This requirement does not apply to Ergon Energy's distribution area.

- (b) AEMO must prepare a NSLP by each Profile Area in accordance with section 11 of Metrology Procedure: Part B and apply it by Profile Area to the *metering data* from type 6 *metering installations* to produce *interval metering data* for type 6 *metering installations*.
- (c) This requirement only applies to the Jurisdiction specified in the following table:

Jurisdiction	Variation in accordance with Jurisdictional policy
Queensland, Australian Capital Territory	AEMO must enable the transfer to AEMO of parameters for the calculation of a weekly load scaling factor, which represents the <i>estimated data</i> for First-Tier Controlled Loads.

13. Emergency Priority Procedures

13.1. Criteria for determining emergency condition

While AEMO does not intend to restrict LNSPs and MCs from agreeing on a definition of 'emergency condition' in their service agreements, the definition must take into consideration the following criteria:

- Unplanned disruption to power supply to one or more Sites, regardless of duration.
- Risk of environmental damage, injury or fatality to any person from *distribution network* equipment due to their proximity to that equipment.
- Potential for or the presence of risk to public safety.
- Mandatory restriction of power supply.
- Disruption to communications network used in the delivery of *metering data*.
- Operational difficulties due to acts of nature, such as flooding and cyclones.

13.2. Metering installations affected

- LNSPs and MCs may adopt different definitions of 'emergency condition' where Accumulation Meters are situated and where Interval Meters are situated.
- In no circumstances will type 7 *metering installations* be affected by an 'emergency condition'.

13.3. Prioritisation of services by MC in emergency condition

LNSPs may prioritise the delivery of services from MCs by agreement provided that those services that are required for safety purposes, such as *disconnection* or *reconnection* must be prioritised over those services that are required solely for commercial reasons.

13.4. Other laws prevail

- (a) Nothing in section 13, or in a services agreement between an LNSP and MC, overrides any requirement to comply with the NER or any other law relating to the safety of any person, property or the environment.
- (b) Whilst an MC may agree to supply services to an LNSP related to an emergency condition, the MC is not able to contract out of its obligations in the NER through that agreement.

14. Shared Fuse Arrangements

- (a) Local Network Service Providers (LNSPs) must identify, record, and maintain Shared Fuse Arrangements through the Shared Isolation Point Flag in MSATS for every *connection point* that is part of each specific Shared Fuse Arrangement, as specified in the NER and the MSATS Procedures.
- (b) FRMPs and MCs must notify the LNSPs of any new Shared Fuse Arrangements or any changes to existing Shared Fuse Arrangements for the *connection points* relevant to them, as specified in the NER and the MSATS Procedures.
- (c) MPB must notify the MC or the FRMP of any new Shared Fuse Arrangements or any changes to existing Shared Fuse Arrangements for the *connection points* relevant to them, as specified in the MSATS Procedures.
- (d) Participants may access existing *connection points*' Shared Fuse Arrangements information that is available in the MSATS Standing Data as specified in the MSATS Procedures. Shared Fuse Arrangements for *connection points* are stored in the Shared Isolation Point Flag field in MSATS which is discoverable via NMI Discovery in MSATS.
- (e) The following diagrams show the correct use of Shared Isolation Point Flags:

Diagram 1 – Example where all meters have Shared Fuse Arrangements

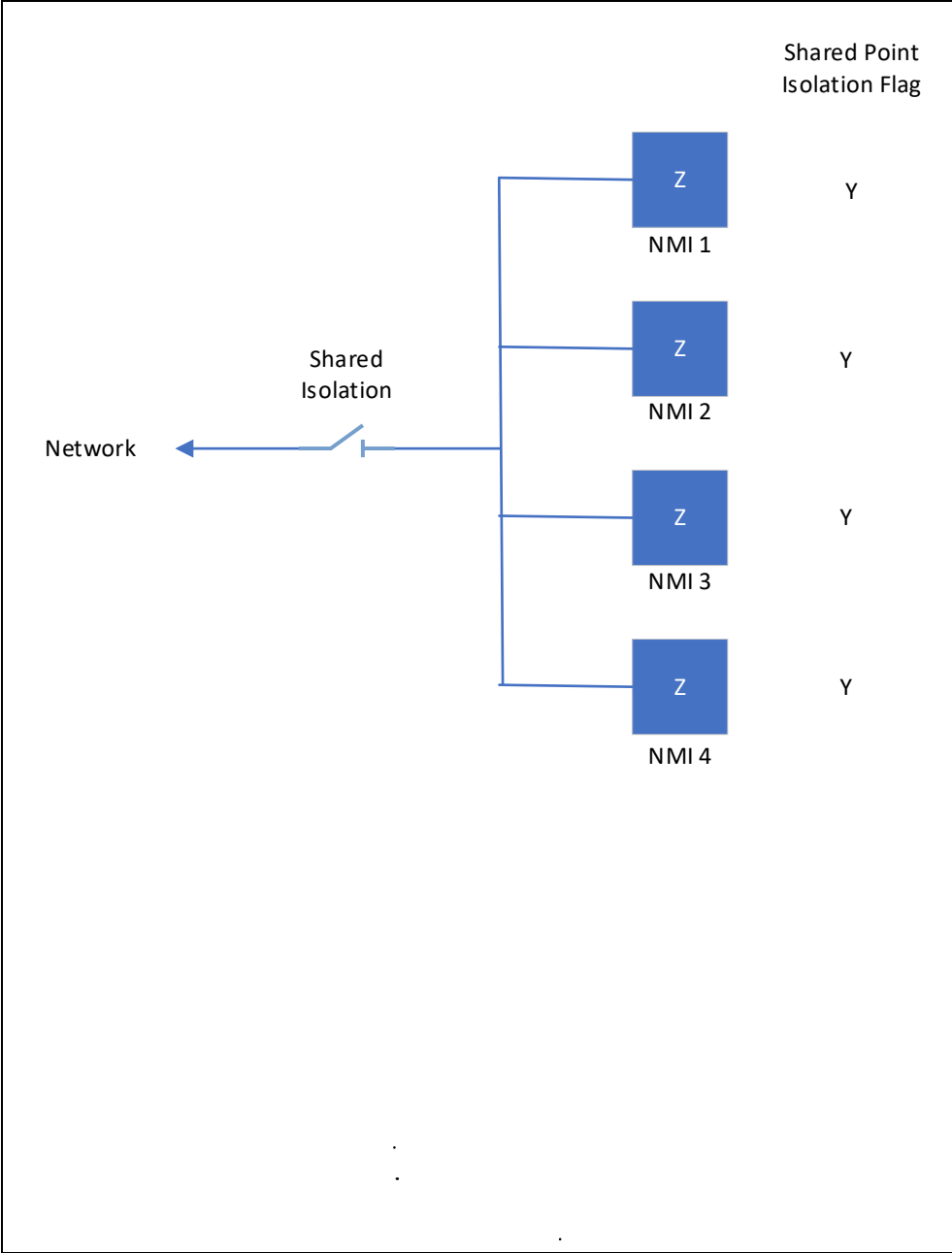

Diagram 2 – Example of one meter with Individual Isolation

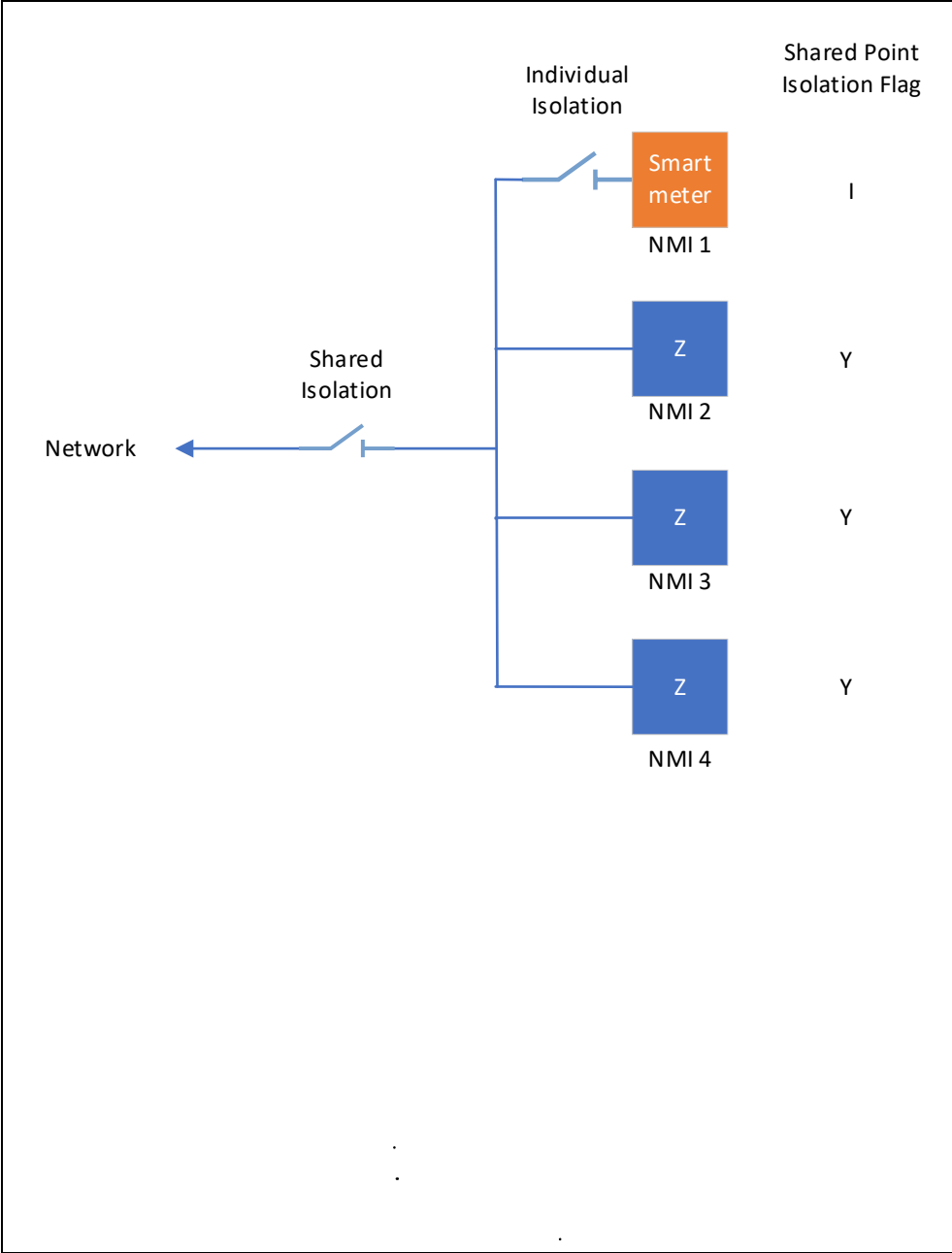

Diagram 3 – Example of all meters with Individual Isolation

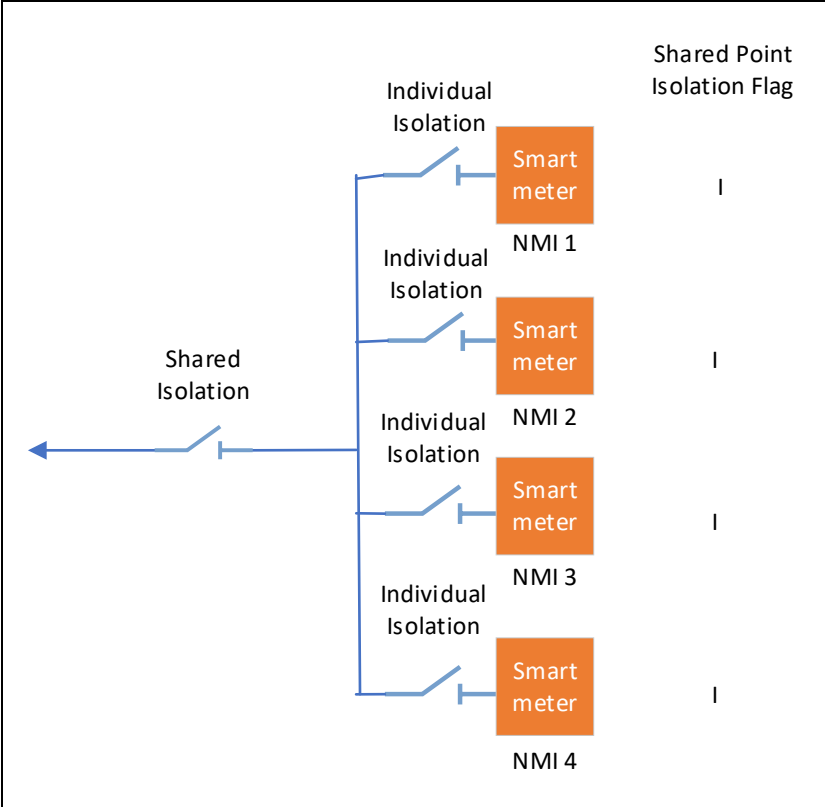

Diagram 4 – Example of one meter with no Shared Fuse Arrangement

